

SYM	DWG.NO	CHANGE NO	DATE	REV'D BY
△	ALL	1LE0005	'16. 3. 3	K.Nakada
△	ALL	1BE0005	'19.10.28	K.Nakada
△	ALL	1BE0006 異記訂正	'20. 6.23	K.Nakada

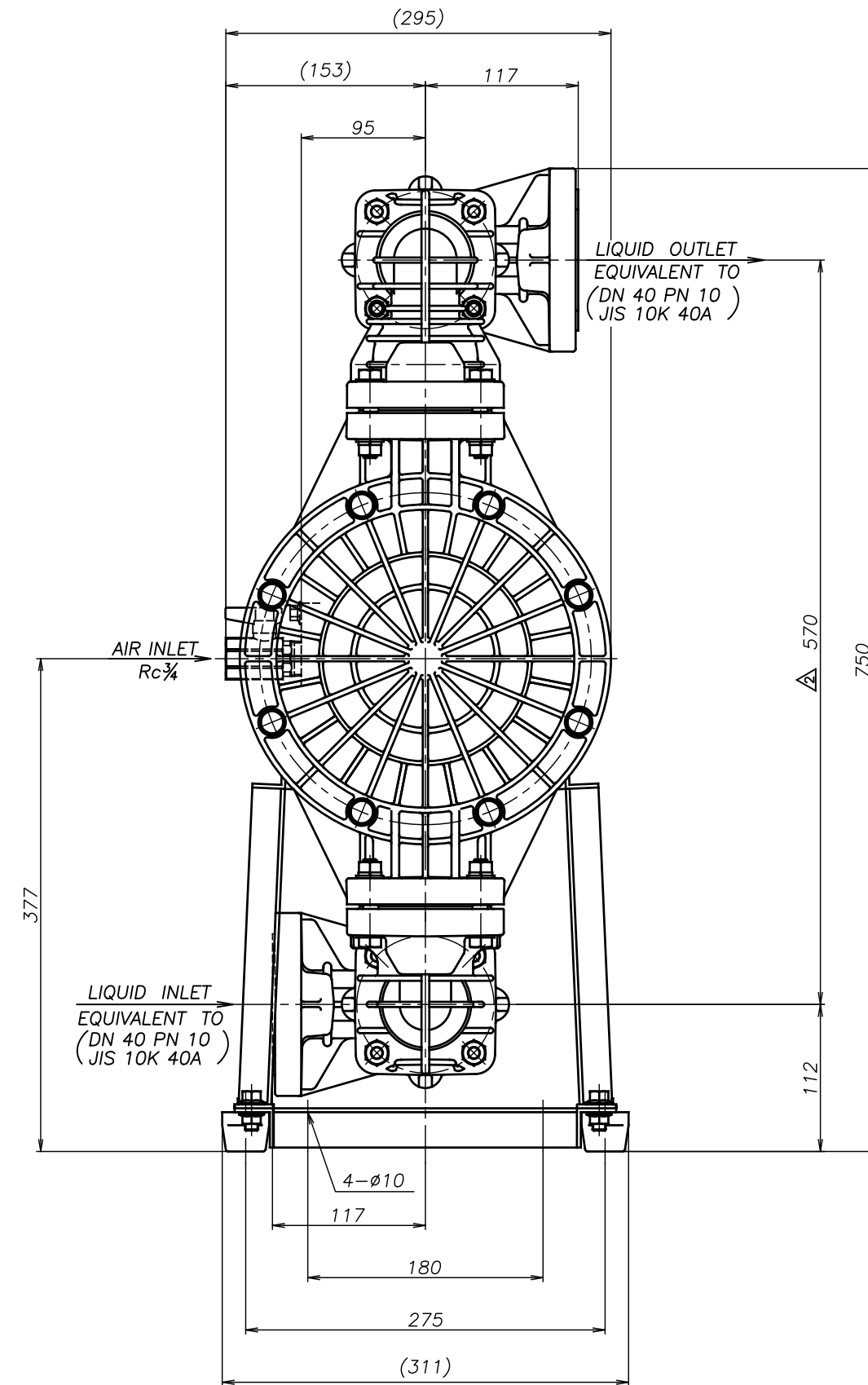
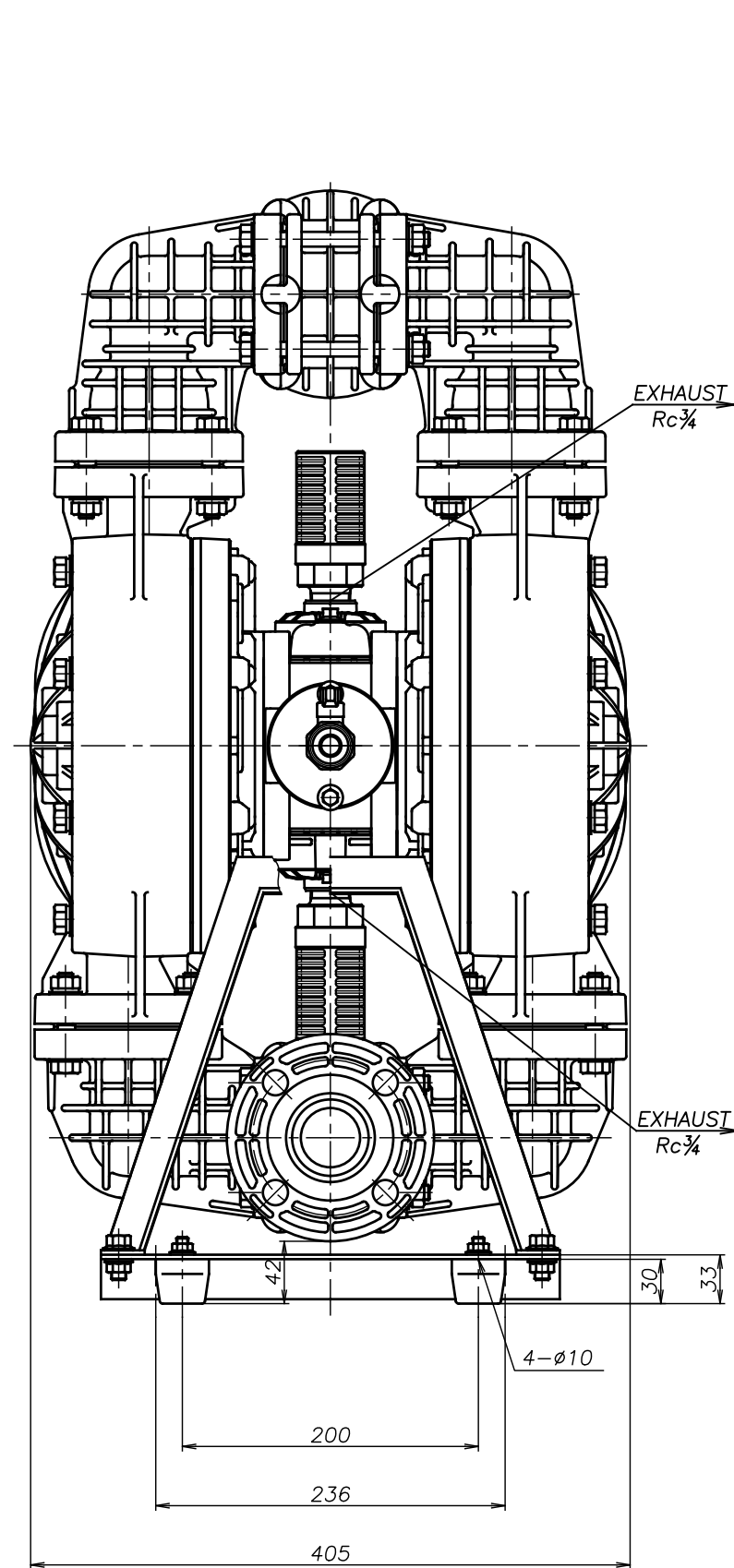

△TC-X400GSJ-M	THIRD ANG. PROJ.	DWG.NO.
	SCALE	Free 1L00025YP-C
△TC-X400GHJ-M	THIRD ANG. PROJ.	DWG.NO.
	SCALE	Free 1L00024YP-C
△TC-X400GTJ-M	THIRD ANG. PROJ.	DWG.NO.
	SCALE	Free 1L00023YP-C
△TC-X400GVJ-M	THIRD ANG. PROJ.	DWG.NO.
	SCALE	Free 1L00022YP-C
△TC-X400GEJ-M	THIRD ANG. PROJ.	DWG.NO.
	SCALE	Free 1L00021YP-C
△TC-X400GNJ-M	THIRD ANG. PROJ.	DWG.NO.
	SCALE	Free 1L00020YP-C

APP'D BY	'20. 8.18	S.Murata	THE DWG. OF:
CHECKED BY	'20. 8.18	K.Nakano	ダイヤフラムポンプアセンブリ
DRAWN BY	'20. 8.18	K.Nakada	DIAPHRAGM PUMP ASSEMBLY
			△TC-X400GCJ-M
			THIRD ANG. PROJ.
			DWG.NO.
			SCALE
			Free 1L00019YP-C

YTS Co., Ltd JAPAN