

SYM	DWG.NO	CHANGE NO	DATE	REV'D BY
△	ALL	1DE0026 構成変更	'20.10.29	K.Nakada
△	ALL	1DE0030 表記変更	'22. 3.16	K.Nakada
✓	1D00126YP-A	1DE0048	'24.12. 6	K.Nakada

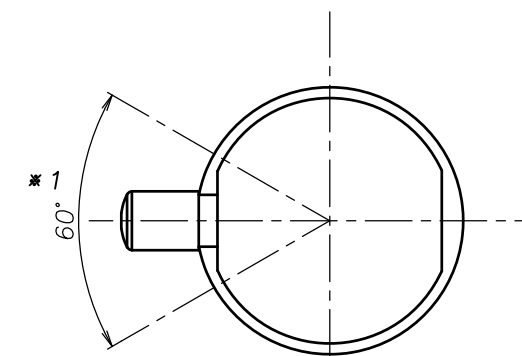
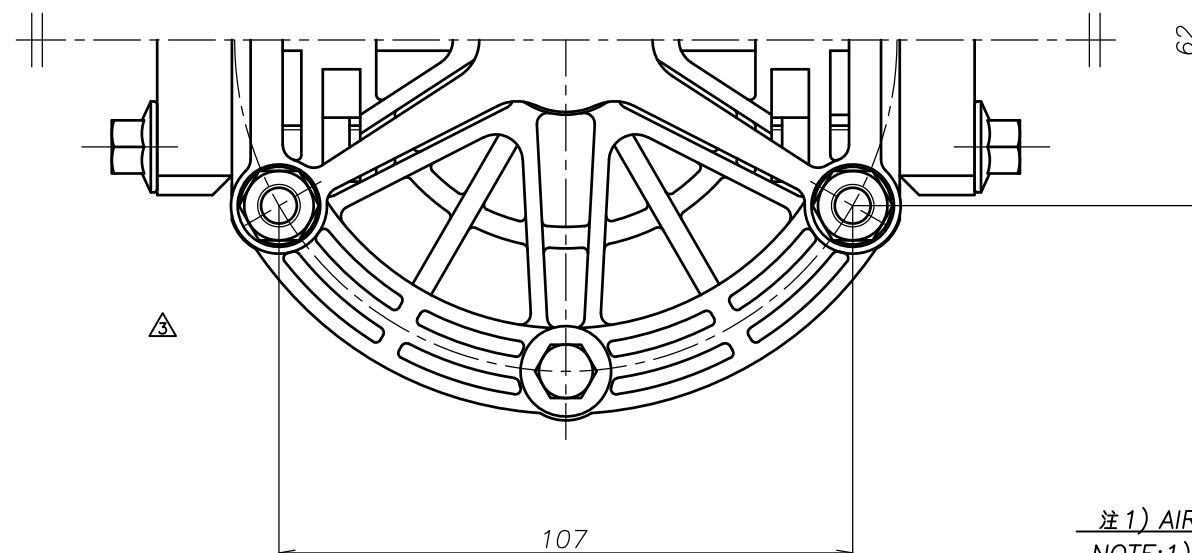
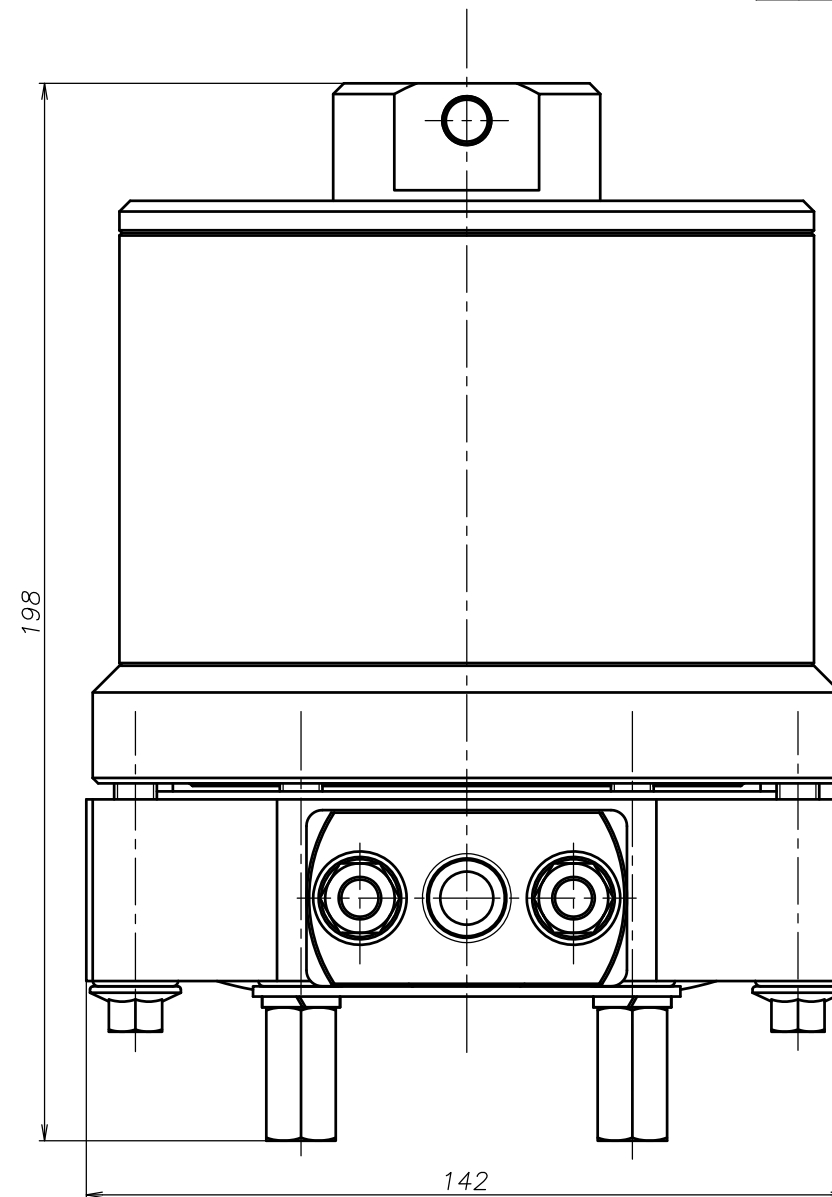
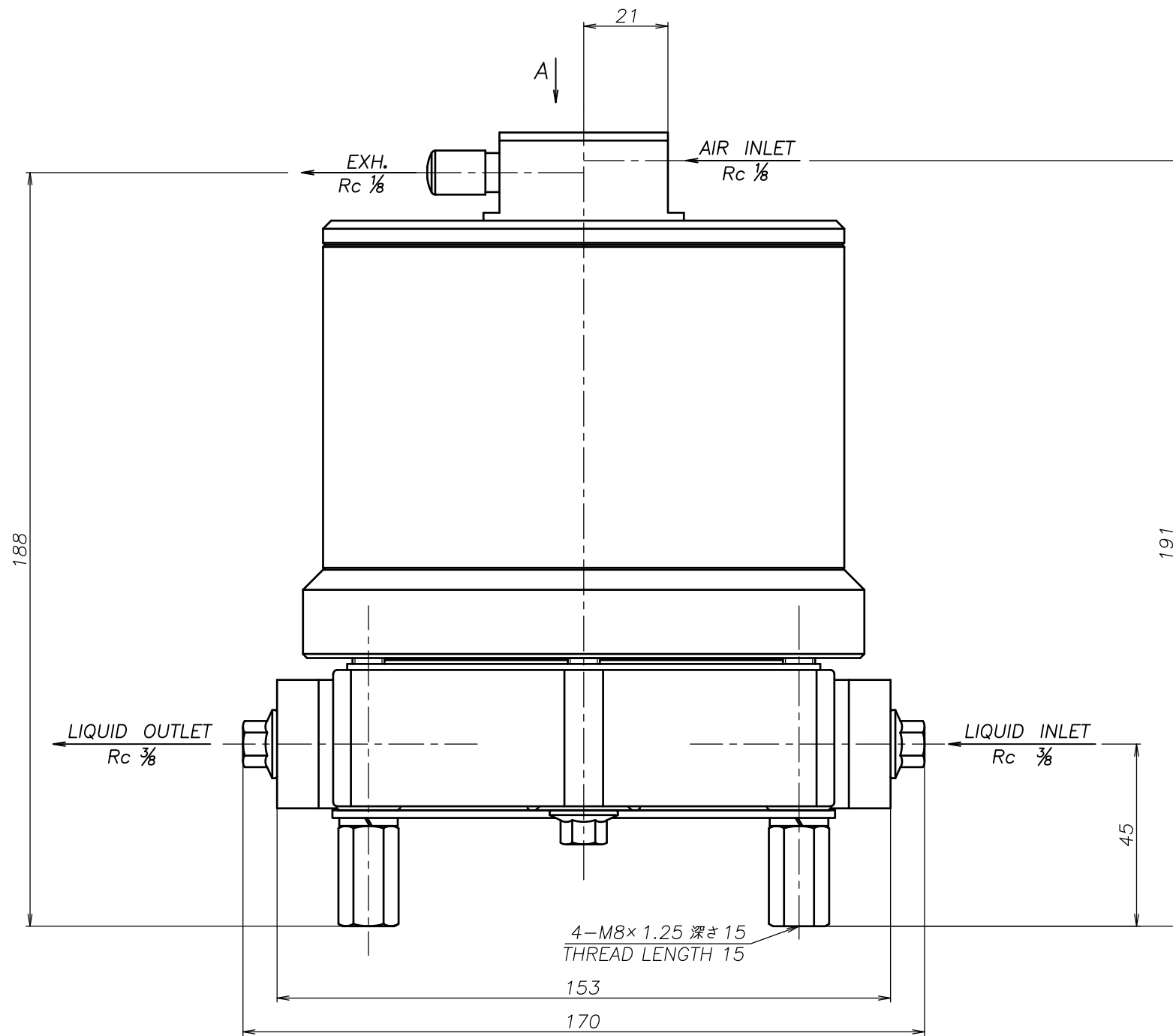

A部分矢視図  
PARTIAL VIEW A

注1) AIR INLET, EXH.は \*1 の範囲で固定されています  
NOTE:1) AIR INLET & EXH. port are fixed in the range of \*1.

THE DWG. OF:  
ダンパ アセンブリ  
DAMPER ASSEMBLY  
CF-X10PW  
THIRD ANG. PROJ. DWG.NO.  
SCALE Free 1D00126YP-A

THE DWG. OF:  
ダンパ アセンブリ  
DAMPER ASSEMBLY  
CF-X10PS  
THIRD ANG. PROJ. DWG.NO.  
SCALE Free 1D00112YP-E

THE DWG. OF:  
ダンパ アセンブリ  
DAMPER ASSEMBLY  
CF-X10PH  
THIRD ANG. PROJ. DWG.NO.  
SCALE Free 1D00111YP-E

THE DWG. OF:  
ダンパ アセンブリ  
DAMPER ASSEMBLY  
CF-X10PT  
THIRD ANG. PROJ. DWG.NO.  
SCALE Free 1D00110YP-E

THE DWG. OF:  
ダンパ アセンブリ  
DAMPER ASSEMBLY  
CF-X10PN  
THIRD ANG. PROJ. DWG.NO.  
SCALE Free 1D00109YP-E

APP'D BY '24.12. 6 T.Terai  
CHECKED BY '24.12. 6 Y.Takahashi  
DRAWN BY '24.12. 6 M.Natori

YTS JAPAN Co., Ltd

THE DWG. OF:  
ダンパ アセンブリ  
DAMPER ASSEMBLY  
CF-X10PC  
THIRD ANG. PROJ. DWG.NO.  
SCALE Free 1D00108YP-E