

SYM	DWG.NO	CHANGE NO	DATE	REV'D BY
△	ALL	1ME0023	'18. 1.16	K.Sugaya
△	ALL	1BE0005	'19.10.28	K.Nakada
△	ALL	1BE0006 異記訂正	'20. 6.23	K.Nakada

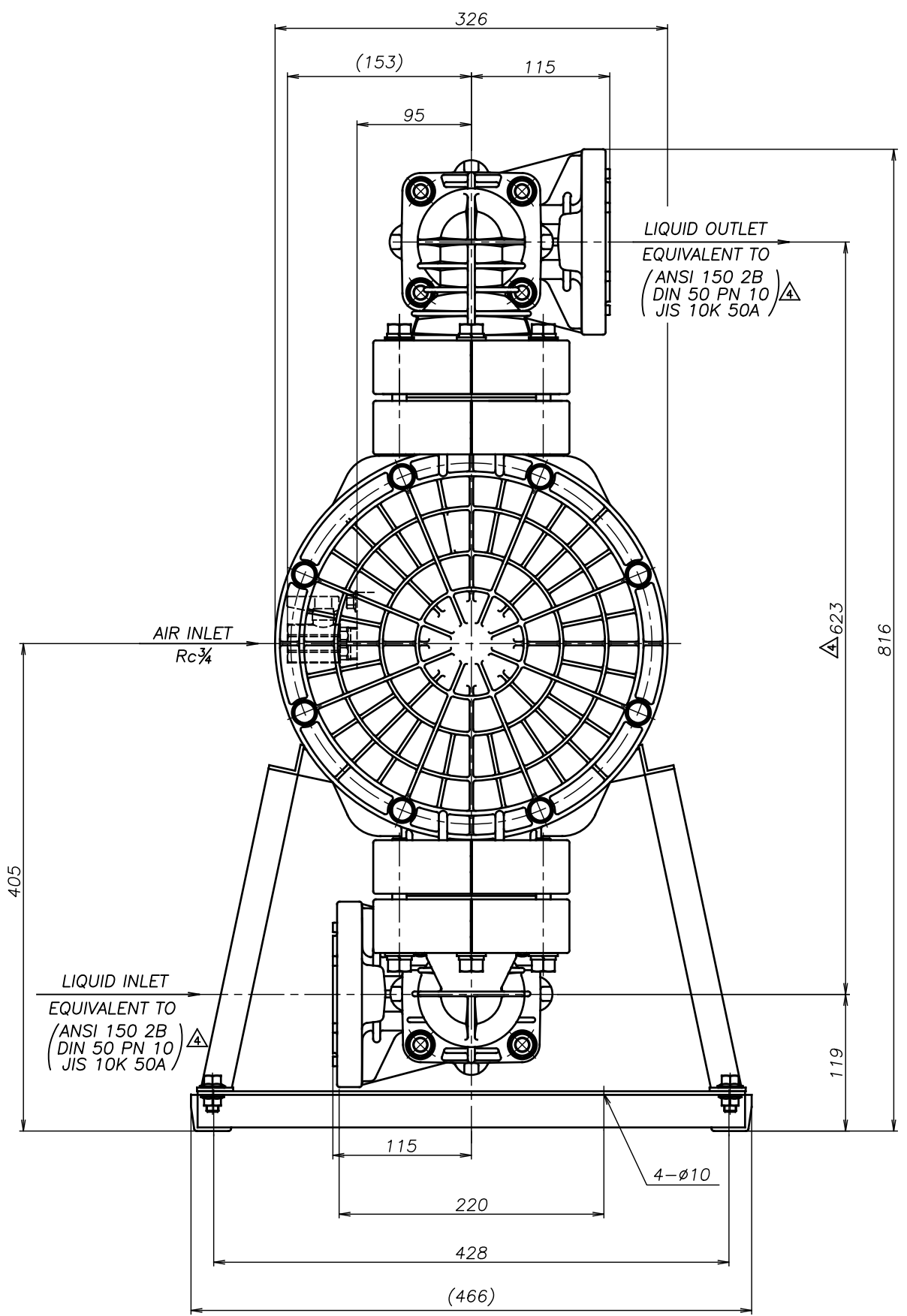
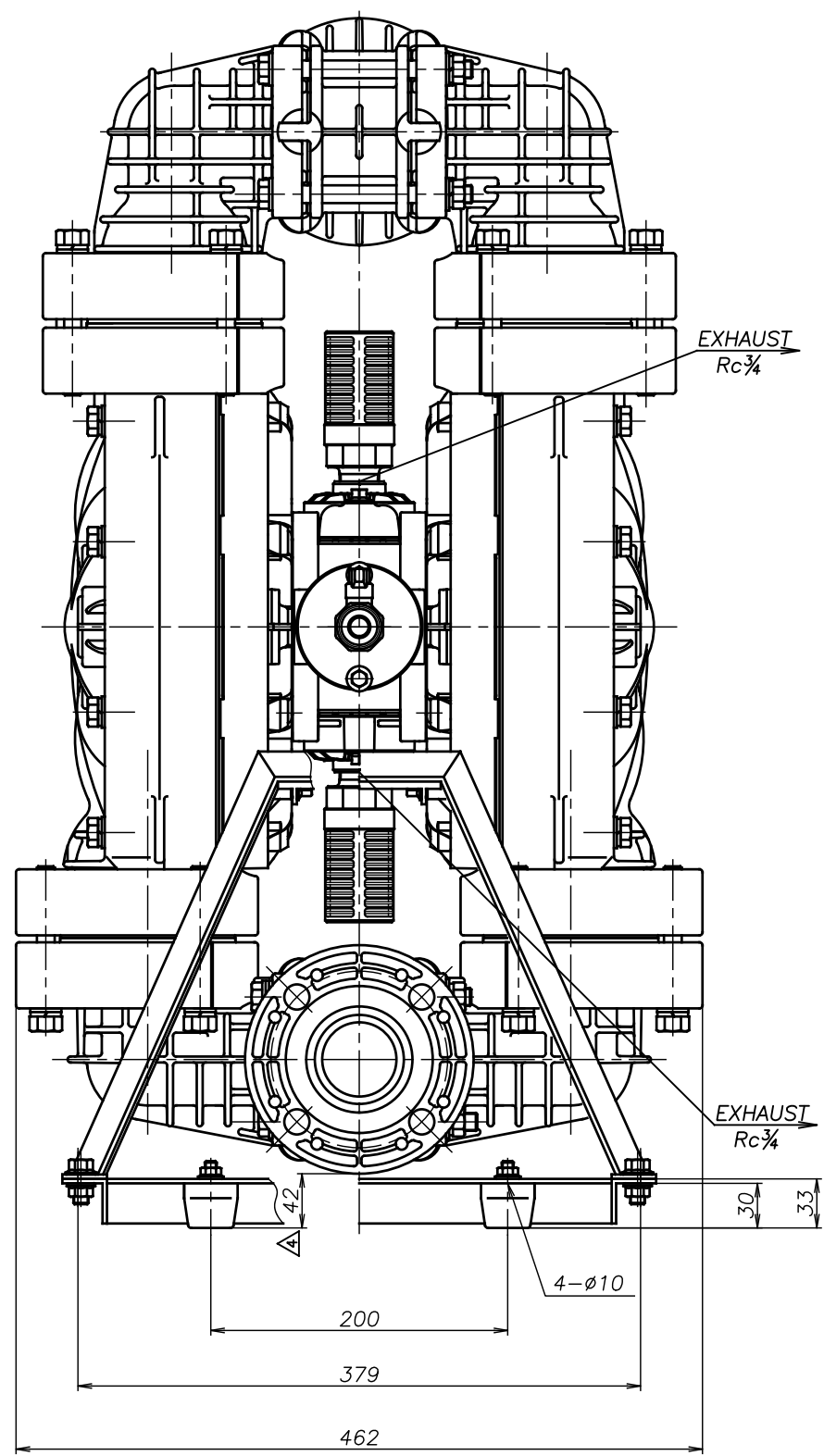

△△500 VSJ-M	THIRD ANG. PROJ.	DWG.NO.
	SCALE Free	1M00040YP-E
△△500 VHJ-M	THIRD ANG. PROJ.	DWG.NO.
	SCALE Free	1M00039YP-E
△△500 VTJ-M	THIRD ANG. PROJ.	DWG.NO.
	SCALE Free	1M00038YP-E
△△500 VVJ-M	THIRD ANG. PROJ.	DWG.NO.
	SCALE Free	1M00037YP-E

APP'D BY	'20. 6.23	S.Murata	THE DWG. OF:
CHECKED BY	'20. 6.23	K.Nakano	ダイアフラムポンプアセンブリ
DRAWN BY	'20. 6.23	K.Nakada	DIAPHRAGM PUMP ASSEMBLY
			△△500 VEJ-M
			THIRD ANG. PROJ.
			DWG.NO.
			SCALE Free
			1M00036YP-E

YTS Co., Ltd JAPAN